

centrodyne

Silent 600 Series Taximeter Operating Instructions



www.centrodyne.com

Centrodyne Corp. of America

75 Ethan Allen Drive
South Burlington, VT, USA
05403
Tel: (802) 658-4715
Fax: (802) 658-4717
Toll Free: (800) 655-5575
Email: salesusa@centrodyne.com

Centrodyne Inc.

3485 Thimens blvd.
Montreal, Quebec, Canada
H4R 1V5
Tel: (514) 331-8760
Fax: (514) 339-1078

Email: sales@centrodyne.com

"SILENT 610/620/150"* TAXIMETER & PRINTER OPERATING INSTRUCTIONS

Operation of the taximeter is controlled by the 4 push buttons on the face of the unit

HIRED

When the taximeter is off or "VACANT", you may hire the meter by pressing the HIRED button once. The meter will display the initial or drop charge in the fare display and the word HIRED will be displayed. When the taximeter is HIRED the meter will automatically be in TIME ON.

Some versions of meter require the driver to enter the number of passengers in the car prior to going HIRED. To do this: Press the HIRED (SW1) button. A blinking "1" appears in the FARE window. Press SW3 to increment the number of passengers. Press SW4 to accept the number in the FARE window as the number of passengers. The meter goes into HIRED mode.

If no buttons are pressed for a period of 10 seconds (may vary by meter configuration) the meter will automatically switch to HIRED mode, saving the current value in the FARE window as the number of passengers.

While in the HIRED state it will not be possible to change to any other state except HIRED TIME OFF.

HIRED - TIME OFF

After the taximeter has been HIRED you may place the meter in TIME OFF by pressing the TIME OFF button once. The meter will now display TIME OFF. Time charges will not be accumulated in this state.

To resume accumulating time charges, press the TIME OFF button once.

While in the HIRED TIME-OFF state it is only possible to change to HIRED Time On or VACANT states.

EXTRAS

If EXTRAS are programmed into your meter, ensure the meter is HIRED Time On and press the EXTRAS button once. The extras amount will appear in the EXTRAS display. Continue to press the EXTRAS button to add to the amount currently displayed (the extras increment is pre-programmed).

While in the HIRED Time On state it is only possible to change to HIRED TIME OFF.

SUMMING FARE AND EXTRAS

To add the FARE and EXTRAS amount, ensure the meter is HIRED TIME OFF, and press the EXTRAS button once. The meter will now display the total of the Fare and Extras in the Fare display, for five seconds.

VACANT

To place the meter in VACANT or off state, ensure the meter is HIRED TIME OFF, and press the HIRED button once. The meter will display the word VACANT.

RATE

If more than one rate is programmed into the taximeter (maximum of 4), you may change RATES when the meter is VACANT. To change rates, ensure meter is VACANT, and press the RATE button to select Rates 1 through 4.

16-Rate Meter

Some meter versions may have more than 10 rates. If this is the case then rates greater than 9 are displayed as follows:

In VACANT mode the tens digit is displayed in the rightmost digit of the EXTRAS window, while the ones digit is displayed in the RATE window.

In HIRED mode the tens digit is not displayed in the EXTRAS window. Only the ones digit of the rate is displayed in the rate window. To differentiate between rates 1-9 and 10-19 the ones digit is blinking for rates greater than 9. So a 2 in the RATE window indicates rate 2 while a blinking 2 in the RATE window indicates rate 12.

STATISTICS DISPLAY

The STATISTICS or TOTALS may be viewed when the meter is VACANT. Press the EXTRAS button in succession to display the following on the taximeter:

ITEM	DESCRIPTION
1	Total Fares
2	Total Extras
3	Total Tax (if applicable)
4	Total Miles (km)
5	Total Paid Miles (km)
6	Number of Trips
7	Calibration
1 ¹	Time of Day
2 ¹	Date
3 ¹	Year - Day of Week

STATISTICS RECEIPT

To print a statistics receipt, ensure the meter is VACANT, press the EXTRAS button once to enter statistics, and then press the TIME OFF button to print the receipt.

FARE RECEIPT

The customer fare receipt is printed from the VACANT state, **except when meter is programmed for DAILY STATISTICS (see DAILY DRIVER STATS)**. At the end of the trip, after the meter has been placed in VACANT, press the TIME OFF button once to print the fare receipt. The total fare will be displayed on the meter.

PAPER FEED

Paper should be loaded into the meter when VACANT. See last pages of this booklet for instructions.

Note 1: Requires RTC (real time clock) factory option and, these item numbers flash to identify clock/calendar.

DAILY DRIVER STATISTICS (Option)

DAILY STATISTICS

In addition to the **TOTAL STATS** included with every “**Silent 610**” and “**Silent 620**” **Taximeter**, the meters may also display **DAILY STATS** (and print with the Silent 620).

The “**Silent 610**” and “**Silent 620**” **Taximeters** continuously accumulate totals or statistics. The **DAILY STATS** accumulated by the meters are:

DAILY STATS
FARES
EXTRAS
TAX (if applicable)
DISTANCE
PAID DISTANCE
of TRIPS

The **DAILY STATS** may be viewed when the taximeter is VACANT, by pressing the Time-Off button (SW2). Sequential presses of the Time-Off button will display the above. Note that the **Stat** light blinks on and off when viewing **DAILY STATS**.

When programmed for **DAILY STATS**, the “**Silent 620**” **Taximeter** uses the Rate button (SW4) to print the **DAILY STATS**. To print a **DAILY STATS** receipt, first press the Time-Off button (SW2) from Vacant to view **DAILY STATS**, then press the Rate button (SW4) to print the **DAILY STATS** receipt.

RESETTING DAILY STATS

Perform the following steps to reset the **DAILY STATS**:

- 1) ensure the meter is VACANT
- 2) press the Time-Off button (SW2) to view the **DAILY STATS**
- 3) immediately press the Hired button (SW1), followed by the Rate button (SW4)

The **DAILY STATS** should now be reset, except if the taximeter has been programmed with Password protection (see programming manual).

Perform the following to reset **DAILY STATS** if the taximeter has Password protection:

- 1) after performing the previous three steps, the Fare window will display **00000** and the Extras window will display **00**. The Extras display is a counter showing the number of times the **DAILY STATS** has been reset. A five digit password must now be entered into the Fare window.
- 2) using the standard programming button sequence, enter the five digit password to reset the **DAILY STATS**.

TOTAL STATISTICS

The **TOTAL STATS** may be viewed by pressing the Extras button (SW3) when the meter is Vacant. Sequential presses of the Extras button will display the following:

TOTAL STATS
FARES
EXTRAS
TAX (if applicable)
DISTANCE
PAID DISTANCE
of TRIPS

When programmed for **DAILY STATS**, the “**Silent 620**” **Taximeter** uses the Rate button (SW4) to print both Customer and Totals receipts. When the meter is Hired/Time-Off, you may print a **Customer Receipt** by pressing the Rate button (SW4). To print a **TOTAL STATS** receipt, first press the Extras button (SW3) from Vacant to view **TOTAL STATS**, then press the Rate button (SW4) to print the **TOTAL STATS** receipt.

RESETTING TOTAL STATS

The **TOTAL STATS** may be reset to zero *if* the taximeter has been programmed to allow Total Statistics reset (see programming manual). Perform the following to reset **TOTAL STATS**:

- 1) ensure the meter is VACANT
- 2) press the Extras button (SW3) to view the **TOTAL STATS**
- 3) immediately press the Hired button (SW1), followed by the Rate button (SW4)

The **TOTAL STATS** should now be reset.

WIRELESS CREDIT CARD OPERATING INSTRUCTIONS

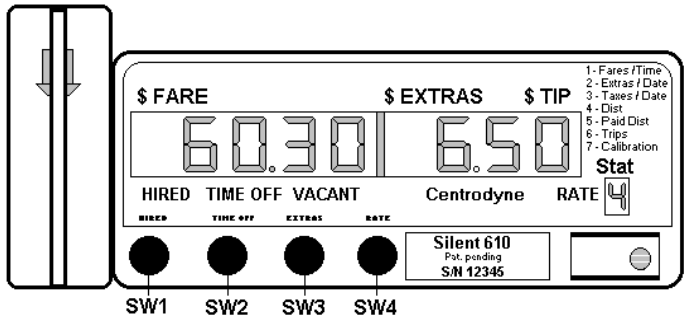

CREDIT CARD SALE

1. Press SW1 "HIRED" to HIRE the meter.
2. Press SW3 "EXTRAS" to enter EXTRAS, if any.
3. Press SW2 "TIME-OFF" to go TIME-OFF.
4. Swipe credit card through card reader in the direction of the arrow imprinted on the card reader. TIME-OFF light flashes, indicating card read successfully.

Option 1: Driver **does not know** the \$Tip amount in advance.

5. Hold down SW4 "RATE" for 3-4 seconds until receipt starts printing.
6. Receipt is passed to passenger who enters tip, signs receipt and passes receipt back to driver.
7. Press SW4 "RATE" to start \$TIP entry. "00.00" is displayed. The first "0" flashes on and off, indicating the number may be edited (using SW3).
8. Press SW2 "TIME-OFF" to move flashing number to desired position.
9. Press SW3 "EXTRAS" to enter the amount in the position.
10. When correct amount is displayed, press SW4 "RATE" to end the \$Tip entry.

Option 2: Driver **does know** \$Tip amount before printing receipt.

5. Press SW4 "RATE" to start \$TIP entry. "00.00" is displayed. The first "0" flashes on and off, indicating the number may be edited (using SW3).
6. Press SW2 "TIME-OFF" to move flashing number to desired position.
7. Press SW3 "EXTRAS" to enter the amount in the position.
8. When correct amount is displayed, press SW4 "RATE" to end the \$Tip entry.
9. Hold down SW4 "RATE" for 3-4 seconds to print driver receipt¹.
10. Receipt is passed to passenger for signature and returned to driver.
11. Press SW2 "TIME-OFF" to send the transaction. "TIME-OFF" light flashes fast.
12. When the approved or declined* message is received, the meter will print the passenger receipt. Tear off receipt and pass to passenger. Press SW1 to go VACANT.

¹ If paper runs out, press SW1 to restart. Replace paper roll and swipe card again.

² If paper runs out, replace paper roll and press SW2 to print a duplicate receipt.

³ Where permitted.

CREDIT CARD TRANSACTION REVERSAL AND CREDIT

If an error was made on a completed (approved) transaction, such as an incorrect \$Tip amount being charged, a Credit Return may be performed. The taximeter **MUST** continue to display the credit sale amount with the TIME-OFF flashing.

1. Press SW3 "EXTRAS". Returns the meter to TIME-OFF not flashing.
2. Swipe the original credit card as before. The TIME-OFF light flashes and the driver's ****CREDIT**** receipt is automatically printed. Pass receipt to the passenger, who signs receipt and returns receipt to driver.
3. Press SW3 "EXTRAS" to send the Credit Return transaction. The TIME-OFF light flashes fast.
4. When approval is received, the meter will print the passenger receipt². Tear off receipt and pass to passenger. The APPROVAL or DECLINED number appears on the receipt.
5. The Taximeter returns to TIME-OFF not flashing state and the driver may repeat steps 4 to 7 under CREDIT CARD SALE to the left.

CREDIT CARD PRE-AUTHORIZATION

1. When VACANT, press and hold down SW4 "RATE" for 3-4 seconds until the TIME-OFF light flashes.
2. Swipe credit card through card reader in the direction of the arrow imprinted on the card reader. TIME-OFF light flashes fast.
3. When the approved or declined message is received, the meter will print the appropriate receipt, with amount, for the driver.

NOTE: If the Taximeter does not receive a response within 50 seconds of sending a Sale, Credit or Pre-Auth transaction, it will print a message stating that there was a communication problem and return to the HIRED-TIME-OFF state. You may try again or accept cash payment.

If an error message is received or card is DECLINED you may try again, use another card or accept cash payment. To try again, press SW1, TIME-OFF stops flashing. Repeat steps 4-7.

SILENT 620 PRINTING METER PAPER ROLL INSTALLATION

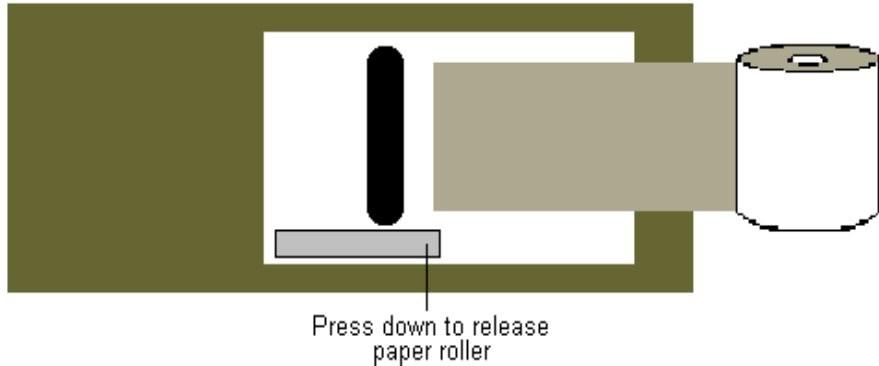

To replace the paper roll in the "Silent 620" High Speed Printing Meter

1. First open the hinged paper door on top of the taximeter and remove the old paper core (and any unused paper).
2. As illustrated above, ensuring the paper has a straight edge and the shiny/glossy side is facing down, extend an inch or two of paper into the case towards the print mechanism.
3. Gently feed the paper under the black roller. The printer will automatically detect the paper and feed it through the print mechanism.
4. The paper may also be fed manually through the printer. Press down on the roller release bar and gently push the paper under the black roller and through the print mechanism (the auto paper feed will also activate). When the paper is fed out the top of the printer, close the roller release bar.
5. Feed the paper through the slot in the hinged door, and close and latch the door.

SILENT 150 REMOTE PRINTER PAPER ROLL & RIBBON INSTALLATION

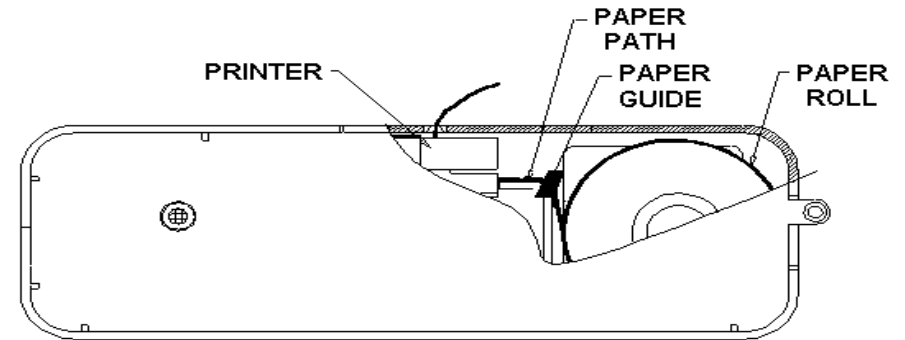

To replace the paper roll in the "Silent 150" Remote Printer

1. First open the hinged paper door on top of the printer and remove the old paper core (and any unused paper).
2. As illustrated above, feed the paper under and through the paper guide.
3. The printer will automatically detect the paper and feed it through the print mechanism.
4. The paper feed button located on top of the printer may also be used to assist in loading paper.
5. Close the hinged door allowing the paper to extend out the top.

To replace the ribbon

1. First remove the paper roll.
2. Where indicated on the ribbon, press down to eject & remove the ribbon. Insert the replacement ribbon into the printer in the same direction as the one removed, ensuring the exposed portion of the ribbon is behind the silver metal edge of the printer, and gently press down on both sides of the ribbon.